



Datasheet

ALTERA M

Coordinate Measuring Machine

8.7.6

10.7.6



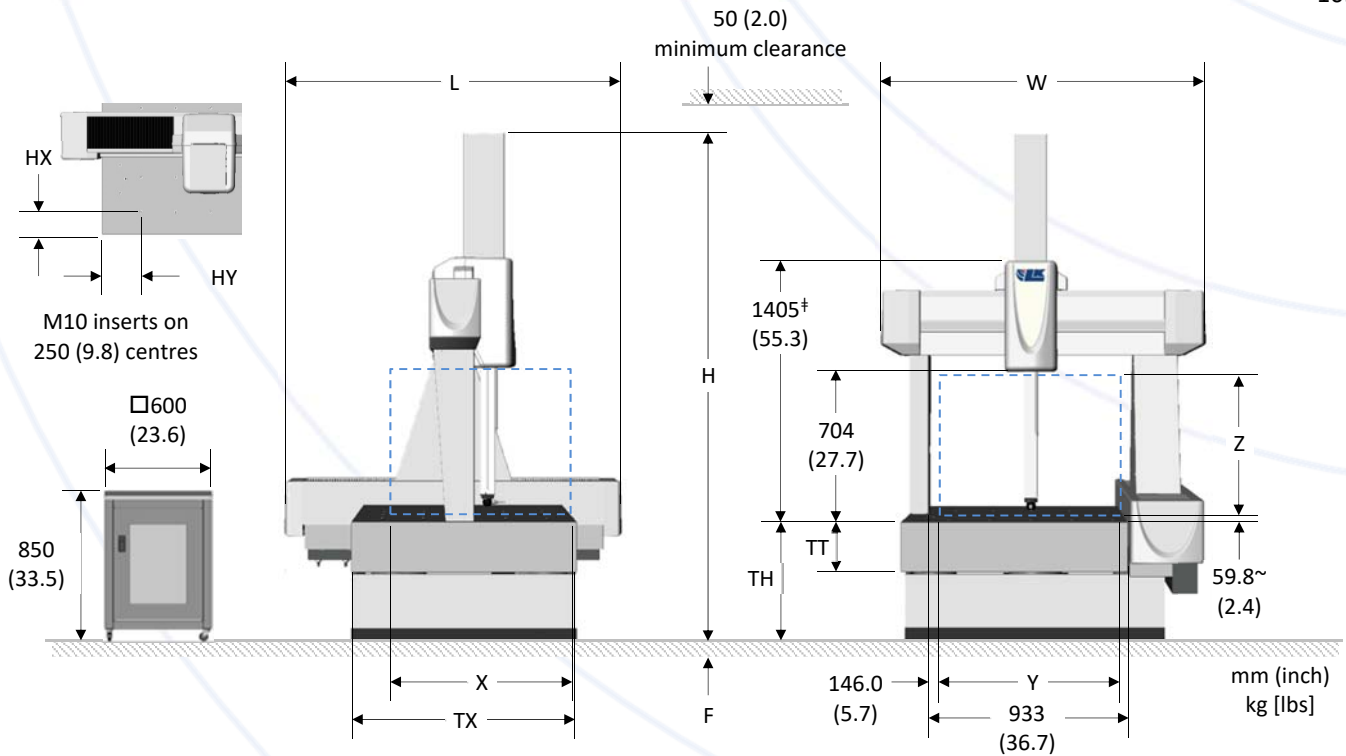

	Travels ¹			Overall			Granite Table					Floor	Table Loading		CMM
	X	Y	Z ²	L	W	H	TX	TT	TH	HX	HY	F ³	Std.	Max. ⁴	Weight
8.7.6	813 (32)	711 (28)	610 (24)	2083 (82.0)	1786 (70.3)	2702 (106.4)	1127 (44.4)	300 (11.8)	710 (28.0)	189 (7.4)	226 (8.9)	35 (1.4)	430 [948]	800 [1764]	1739 [3834]
10.7.6	1016 (40)	711 (28)	610 (24)	2286 (90.0)	1786 (70.3)	2702 (106.4)	1330 (52.4)	300 (11.8)	710 (28.0)	165 (6.5)	226 (8.9)	45 (1.8)	570 [1257]	1000 [2205]	1968 [4339]

¹Maximum travel of probe head index point.

²Z travel for PH10MQ PLUS only, reduce for PH20 by 40mm (1.6"), REVO2 by 120mm (4.7") and SP80 by 120mm (4.7").

³Minimum thickness of homogeneous concrete floor with minimum shear strength of 0.4 N/mm² (58 psi).

⁴Maximum table loading only permissible with workpiece positioned inside triangular area defined by table support centers.

[~]Z travel limit for PH10MQ PLUS only, increase for PH20 by 9.5mm (0.4"), REVO2 by 35.6mm (1.4") and SP80 by 20mm (0.8").

[†]Bridge off table access height excluding lifting equipment and clearances.

TABLE SUPPORT CENTERS

	P	R	S	T	U
8.7.6	957 (37.7)	1115 (43.9)	170 (6.7)	195 (7.7)	564 (22.2)
10.7.6	1160 (45.7)	1115 (43.9)	170 (6.7)	195 (7.7)	665 (26.2)

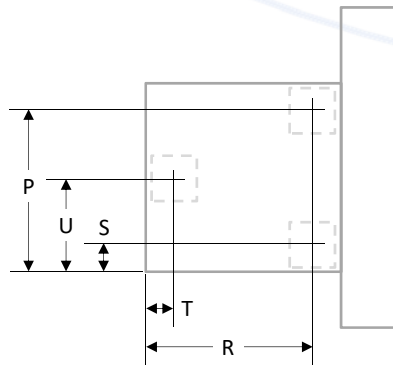

TOUCH PROBE ACCURACY ¹		TP20 ² PH10MQ PLUS	T200 ³ PH10MQ PLUS	SP25M ⁴ PH10MQ PLUS	RSP2 ⁵ REVO2	RSP3 ⁶ REVO2	SP80 ⁷
Length measurement at 18°C to 22°C	E0 MPE E150 MPE	1.5+L/375	1.5+L/375	1.5+L/375	2.5+L/375	1.5+L/375	1.4+L/375
Length measurement 16°C to 26°C	E0 MPE E150 MPE	1.5+3L/375	1.5+3L/375	1.5+3L/375	-	-	1.5+3L/375
Repeatability	R0 MPL	1.5	1.5	1.5	1.5	1.5	1.5

ISO 10360 -3:2001⁸

Rotary table	radial MPE FR tangent MPE FT axial MPE FA	5.6	5.6	5.6		5.6	5.6
--------------	---	-----	-----	-----	--	-----	-----

ISO 10360 -4:2001

Probing accuracy scanning mode	form MPE T _{ij} time MPT t	-	-	2.2 59 sec	3.0 9 sec	3.0 59 sec	1.9 65 sec
--------------------------------	--	---	---	---------------	--------------	---------------	---------------

ISO 10360 -5:2010

Probing accuracy touch mode	form PFTU MPE	2.0	1.5	1.3	2.3	1.6	1.2
Multi stylus fixed head position	form PFTM MPE	4.0	4.0	4.0			
	size PSTM MPE	2.5	2.5	2.5			
	location PLTM MPE	4.0	4.0	4.0			
Multi stylus articulating head	form PFTE MPE	4.0	4.0	4.0			
	size PSTE MPE	2.5	2.5	2.5			
	location PLTE MPE	4.0	4.0	4.0			

LASER SCANNER ACCURACY⁹

ISO 10360 -8:2013		LC15Dx	LC60Dx	L100	XC65Dx	XC65Dx-LS
Probing form	PForm.Sph.1x25 :Tr:ODS,MPE	7	20	15	25	35
Probing dispersion	PForm.Sph.D95% :Tr:ODS,MPL	7.6	36	26	48	60
Probing size All	PSize.Sph.All :Tr:ODS,MPE	15	30	20	45	80
Cone angle		100	125	125	115	125

SPEEDS

Acceleration	2514 mm/sec ²
Velocity	833 mm/sec

Conformance is proven when all errors of indication lie within or on the accuracy specification limits MPE/MPL.

Conformance is unproven when one or more errors of indication lie outside the accuracy specification limits MPE/MPL.

¹ Touch probe accuracy specifications using manufacturer specified test lengths and test sphere with empirical qualification.

E0 MPE E150 MPE Maximum volumetric length measurement error in microns where L is the measured length in millimeters.
R0 MPL Maximum repeatability value in microns using E0 values.
MPE FR MPE FT MPE FA Maximum radial, tangential and axial errors respectively in microns.
MPE T_{ij} MPT t Maximum single stylus form error in microns using scanning mode with time taken in seconds.
PFTU MPE Maximum single stylus form error in microns using touch point mode.

² TP20 standard force module, EM2 module (PH20 E_h MPE only), Ø4x10mm stainless steel shaft stylus, Ø4x30mm tungsten carbide shaft stylus (E_h MPE only), Ø5x20mm star tungsten carbide shaft stylus (P*TM MPE only), touch velocity 0.1m/min, approach 10mm (E_h MPE only), 7mm (PFTU MPE only).

³ TP200 standard force module, Ø4x10mm stainless steel shaft stylus, Ø4x30mm tungsten carbide shaft stylus (E_h MPE only), Ø5x20mm star tungsten carbide shaft stylus (P*TM MPE only), touch velocity 0.1m/min, approach 10mm (E_h MPE only), 7mm (PFTU MPE only).

⁴ SP25M SM25-1 module, SH25-1 stylus holder, Ø4x50mm tungsten carbide shaft stylus, Ø3x21mm stainless steel shaft stylus (P*TM MPE only), touch velocity 0.1m/min, scanning velocity 0.5m/min, approach 10mm (E_h MPE only), 7mm (PFTU MPE only), 50 UPR 2σ filter.

⁵ REVO2 RSP2 module, RSH250 holder, Ø6x10mm stainless steel shaft stylus, touch velocity 0.1m/min, scanning velocity 5.0m/min, approach 10mm (E_h MPE only), 7mm (PFTU MPE only), 50 UPR 2σ filter, helix scan path.

⁶ REVO2 RSP3 module, RSH3-3 holder, Ø5x21mm stainless steel shaft stylus, touch velocity 0.1m/min, scanning velocity 0.5m/min, approach 10mm (E_h MPE only), 7mm (PFTU MPE only), 50 UPR 2σ filter.

⁷ SP80 stylus holder, Ø8x100mm carbon fibre shaft stylus, Ø8x150mm carbon fibre shaft stylus and stainless steel stylus extension (E_h MPE only), touch vel. 0.1m/min, scanning vel. 0.5m/min, approach 10mm (E_h MPE only), 7mm (PFTU MPE only), 50 UPR 2σ filter.

⁸ Rotary table accuracy specifications using manufacturer specified rotary table with Ø400mm (15.7") table top.

⁹ Laser scanner accuracy specifications for CMM with an accuracy of 2+L/350 or better using manufacturer specified test sphere with empirical qualification.

PForm.Sph.1x25:Tr:ODS,MPE Maximum probing form error in microns using 25 representative points in translatory scanning mode.
PForm.Sph.D95%:Tr:ODS,MPL Maximum probing dispersion value in microns using 95% of the measured points in translatory scanning mode.
PSize.Sph.All:Tr:ODS,MPE Maximum probing size error All in microns using all measured points in translatory scanning mode.
Cone angle Region of sphere on which the measured points are selected.

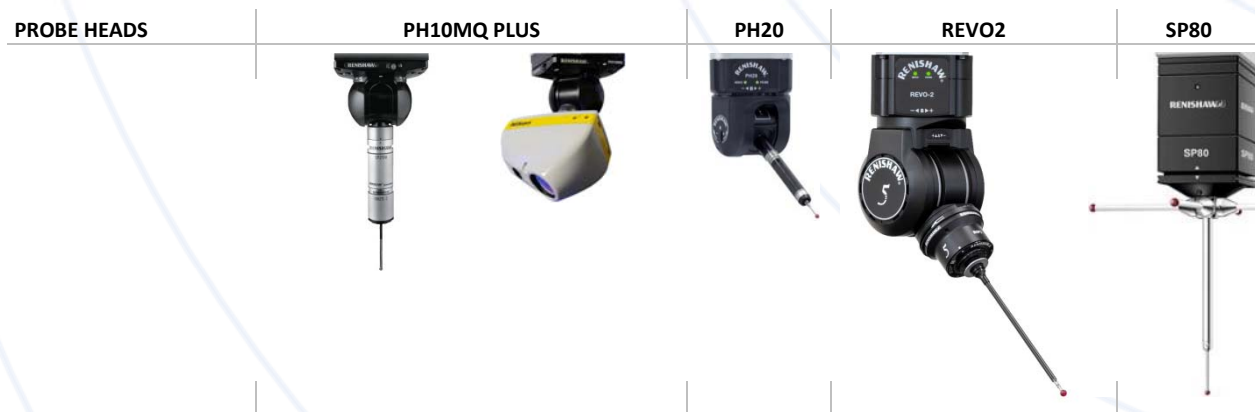

PROBE HEADS	PH10MQ PLUS	PH20	REVO2	SP80
Head type	Indexing head	5-axis head	5-axis head	Fixed head
Head positions	720	Infinite	Infinite	-
Angular tilt	0° to +105° in 7.5° steps	±115°	-100° to +120°	-
Angular rotation	0° to ±180° in 7.5° steps	Continuous	Continuous	-
Probe change rack	MRS ACR3	-	MRS ACR3	MRS ACR3

TOUCH PROBES	TP20	TP200	SP25M	TP20	RSP2	RSP3	SP80
Probe type	Touch trigger	Touch trigger	Scanning	Touch trigger	Tip sensing	Scanning	Scanning
Min. stylus diameter	0.3 (0.012)	0.3 (0.012)	0.5 (0.02)	0.3 (0.012)	0.3 (0.012)	0.5 (0.02)	0.3 (0.012)
Max. stylus length	60 (2.4)	100 (3.9)	400 (15.7)	60 (2.4)	400 (15.7)	800 (31.5)	1000 (39.4)
Max. probe extension	300 (11.8)	300 (11.8)	100 (3.9)	75 (3.0)	-	-	-
Min. probing force	0.055 N	0.02 N	0.1 N	0.055 N	0.05 N	0.1 N	2.2 N
Stylus change rack	MCR20	SCR200	FCR25	TCR20	RCP2	FCR25	SCP80

LASER SCANNERS	LC15Dx	LC60Dx	XC65Dx/-LS	L100
Laser line width	15 (0.6)	60 (2.4)	3x 65 (2.6)	100 (3.9)
Points/sec	70k	75k	75k	200k
Resolution	22 µm	60 µm	65 µm	42 µm
Standoff	68	125	107/202	135

PERIPHERALS				
Controller		NMC300	UCC T5	UCC S5
Controller mounting		Cabinet	Cabinet	Cabinet
Handbox		SOLO	MCU 5	MCU 5
Rotary Table		●	●	●
Automation		●	-	-

● Optional

- Not available

mm (inch)

TECHNICAL FEATURES

X axis guideway	Granite dovetail guideway with bellows covers on primary bridge leg
Y axis guideway	Mono-crystalline alumina ceramic guideway 375 x 120 (14.8 x 4.7) with bellows covers
Z axis guideway	Mono-crystalline alumina ceramic guideway 92 x 80 (3.6 x 3.1) with top-hat cover
X axis friction drive	Chrome-plated hardened steel drive bar with preloaded V roller and DC servomotor
Y axis friction drive	Stainless steel drive belt with preloaded rollers and DC servomotor
Z axis friction drive	Chrome-plated hardened steel drive bar with preloaded V roller and DC servomotor
Linear encoders	0.05µm stainless steel ribbon scale and optical read-head Renishaw TONIC™ system
Counterbalance	Fully adjustable pneumatic Z axis counter balance
Granite table	Granite table flatness according to DIN 876/III : Grade 0
Table inserts	Grid pattern of M10 x 1.5 threaded table inserts on 250 (9.8) centre spacing
Air bearings	Single orifice multi-groove air bearings with 5µm air cushion on all axes
Temperature compensation	Automatic temperature compensation for work piece and all axes
Anti-vibration	Passive elastomer anti-vibration as standard, active pneumatic anti-vibration optional

ENVIRONMENTAL REQUIREMENTS

Ambient temperature	Standard temperature range: 18°C to 22°C Extended temperature range: 16°C to 26°C
Temperature gradient	Standard temperature range: 1°C/h 2°C/24h 1°C/m Extended temperature range: 2°C/h 5°C/24h 1°C/m
Operating temperature	16°C to 30°C
Relative humidity	20% to 80% non-condensing
Floor vibration	Passive anti-vibration: Max. 1.27µm peak-to-peak over 3.5 to 90Hz range Active anti-vibration: Specification on request

SUPPLY REQUIREMENTS

Power supply	115V/20A or 230V/13A 50 to 60Hz single phase regulated to within -5% to +10%
Air consumption	Passive anti-vibration: 4.0 SCFM (115 NI/min) inc. rotary table: 14.0 SCFM (400 NI/min) Active anti-vibration: 5.8 SCFM (165 NI/min) inc. rotary table: 15.8 SCFM (450 NI/min)
Air supply	Min. air supply pressure 6.2 bar (90 psi)
Air quality	Dew point: 2°C Solids: Max. particle size 1.0µm and max. concentration 1mg/cu.m Oil/hydrocarbons: Max. concentration 0.1mg/cu.m

WARRANTY



12 months warranty as standard, extended warranty available on request
Unique 10-year original accuracy guarantee as standard
Terms and conditions apply see LK Metrology website for full details

CONFORMITY



Full CE certification in accordance with the following directives:
Machinery directive 2006/42/EC
Low voltage directive 2014/35/EC
Electromagnetic directive 2014/30/EC