



# Datasheet

## ALTERA S

Coordinate Measuring Machine

8.7.6

10.7.6



# TECHNICAL DATA | Dimensions

**ALTERA S**  
8.7.6  
10.7.6

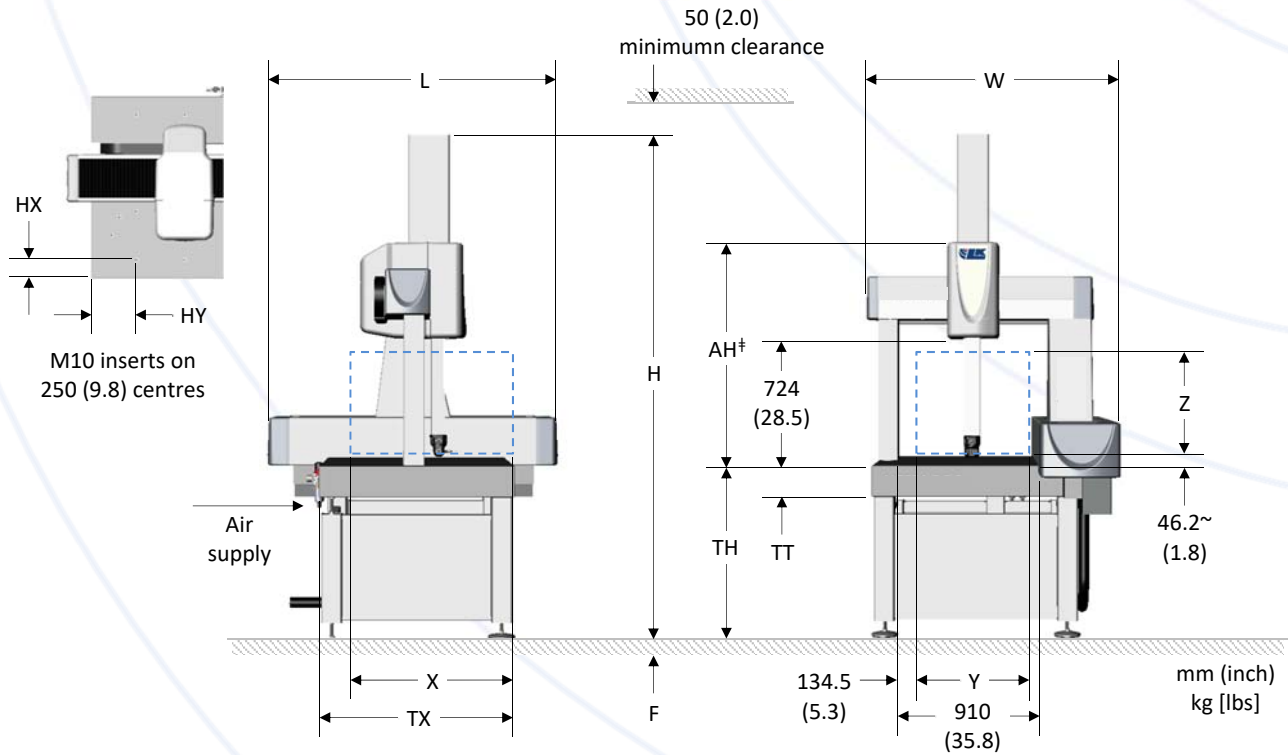

	Travels <sup>1</sup>			Overall			Granite Table					Floor	Access	Table Loading		CMM
	X	Y	Z	L	W	H	TX	TT	TH	HX	HY	F <sup>2</sup>	AH <sup>‡</sup>	Std.	Max. <sup>3</sup>	Weight
<b>8.7.6</b>	813 (32)	711 (28)	610 (24)	1673 (65.9)	1460 (57.5)	2705 (106.5)	1135 (44.7)	175 (6.9)	840 (33.1)	185 (7.3)	145 (5.7)	75 (3.0)	1435 [3164]	250 [551]	378 [833]	892 [1967]
<b>10.7.6</b>	1016 (40)	711 (28)	610 (24)	1876 (73.9)	1460 (57.5)	2705 (106.5)	1243 (48.9)	175 (6.9)	840 (33.1)	185 (7.3)	121.5 (4.8)	85 (3.3)	1484 [3272]	285 [628]	514 [1133]	1029 [2269]

<sup>1</sup>Maximum travel of probe head index point.  
<sup>2</sup>Minimum thickness of homogeneous concrete floor with minimum shear strength of 0.4 N/mm<sup>2</sup> (58 psi).  
<sup>3</sup>Maximum table loading only permissible with workpiece positioned inside triangular area defined by table support centers.  
 ~Z travel limit for PH10T/M PLUS only, for PH20 increase by 2.1mm (0.1"), for MH20i increase by 38.4mm (1.5").  
<sup>‡</sup>Bridge off table access height excluding lifting equipment and clearances.

## TABLE SUPPORT CENTERS

	Type	P	R	S	T	U
<b>8.7.6</b>	Passive AVM	980 (38.6)	1160 (45.7)	60 (2.4)	60 (2.4)	710 (28.0)
	Active AVM	930 (36.6)	1110 (43.7)	110 (4.3)	110 (4.3)	710 (28.0)
<b>10.7.6</b>	Passive AVM	1147 (45.1)	1160 (45.7)	97 (3.8)	60 (2.4)	710 (28.0)
	Active AVM	1102 (43.4)	1110 (43.7)	112 (4.4)	110 (4.3)	710 (28.0)

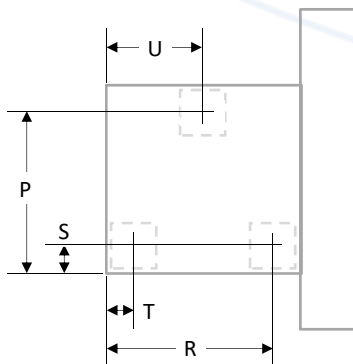

CONTROLLER		Width	Depth	Height	Mounting
<b>NMC100</b>	CMM controller	450 (17.7)	390 (15.4)	150 (5.9)	Desk
	PHC10 head controller	450 (17.7)	390 (15.4)	60 (2.4)	Desk
<b>NMC300</b>	CMM controller	600 (23.6)	600 (23.6)	850 (33.5)	Cabinet
<b>UCC-T5</b>	CMM controller	600 (23.6)	600 (23.6)	850 (33.5)	Cabinet



ALTERA with active anti-vibration mounts (AVM)

TOUCH PROBE ACCURACY <sup>1</sup>		TP20 <sup>2</sup> PH10T/M PLUS	T200 <sup>3</sup> PH10T/M PLUS	SP25M <sup>4</sup> PH10M PLUS	PH20 <sup>2</sup>	
<b>ISO 10360 -2:2001</b>						
Length measurement at 18°C to 22°C	MPE E	2.0+L/400	1.8+L/400	1.8+L/400	2.0+L/400	
Length measurement 16°C to 26°C	MPE E	2.0+3L/400	1.8+3L/400	1.8+3L/400	2.0+3L/400	
Probing accuracy touch mode	form. MPE P	2.8	1.7	1.6	2.8	
<b>ISO 10360 -3:2001<sup>5</sup></b>						
Rotary table	radial MPE FR	6.0	6.0	5.8	6.0	
	tangent MPE FT	6.0	6.0	5.8	6.0	
	axial MPE FA	6.0	6.0	5.8	6.0	
<b>ISO 10360 -4:2001</b>						
Probing accuracy scanning mode	form MPE T <sub>ij</sub> time MPT t	-	-	2.6 55 sec	-	
<b>ISO 10360 -5:2001</b>						
Multi stylus fixed head position	form MPE MF		6.0			
	size MPE MS		4.0			
	location MPE ML		6.0			
Multi stylus articulating head	form MPE AF		6.0			
	size MPE AS		4.0			
	location MPE AL		6.0			
<b>LASER SCANNER ACCURACY<sup>6</sup></b>		LC15Dx	LC60Dx	L100	XC65Dx	XC65Dx-LS
Fixed head sphere test	form PF_SPT	1.9	9.0	6.5	12.0	15.0
Articulating head sphere test	location PF_MOT	3.9	9.0	6.0	9.0	9.0

**SPEEDS**

Acceleration	2290 mm/sec <sup>2</sup>
Velocity	762 mm/sec

Conformance is proven when all errors of indication lie within or on the accuracy specification limits MPE / PF.

Conformance is unproven when one or more errors of indication lie outside the accuracy specification limits MPE / PF.

<sup>1</sup> Touch probe accuracy specifications using manufacturer specified test lengths and test sphere with empirical qualification.

MPE E Maximum volumetric length measurement error in microns where L is the measured length in millimeters.

MPE P Maximum single stylus form error in microns using touch point mode.

MPE T<sub>ij</sub> MPT t Maximum single stylus form error in microns using scanning mode with time taken in seconds.

<sup>2</sup> TP20 standard force module, EM2 module (PH20 MPE E only), Ø4x10mm stainless steel shaft stylus, Ø4x30mm tungsten carbide shaft stylus (MPE E only), Ø5x20mm star tungsten carbide shaft stylus (MPE M\* only), touch velocity 0.1m/min, approach 10mm (MPE E only), 7mm (MPE P only).

<sup>3</sup> TP200 standard force module, Ø4x10mm stainless steel shaft stylus, Ø4x30mm tungsten carbide shaft stylus (MPE E only), Ø5x20mm star tungsten carbide shaft stylus (MPE M\* only), touch velocity 0.1m/min, approach 10mm (MPE E only), 7mm (MPE P only).

<sup>4</sup> SP25M SM25-1 module, SH25-1 stylus holder, Ø4x50mm tungsten carbide shaft stylus, Ø3x21mm stainless steel shaft stylus (MPE M\* / A\* only), touch velocity 0.1m/min, scanning velocity 0.5m/min, approach 10mm (MPE E only), 7mm (MPE P only), 50 UPR 2σ filter.

<sup>5</sup> Rotary table accuracy specifications using manufacturer specified rotary table with Ø400mm (15.7") table top.

<sup>6</sup> Laser scanner accuracy specifications for CMM with an accuracy of 2+L/350 or better using manufacturer specified test sphere with empirical qualification.

PF\_SPT Maximum single probe head position form error in microns using scanning mode.

PF\_MOT Maximum multiple probe head positions location error in microns using scanning mode.

# TECHNICAL DATA | Specification

ALTERA S

8.7.6

10.7.6

TOUCH PROBE ACCURACY <sup>1</sup>		TP20 <sup>2</sup>	T200 <sup>3</sup>	SP25M <sup>4</sup>	PH20 <sup>2</sup>	
ISO 10360 -2:2009		PH10T/M PLUS	PH10T/M PLUS	PH10M PLUS		
Length measurement at 18°C to 22°C	E0 MPE E150 MPE	2.0+L/400	1.8+L/400	1.8+L/400	2.0+L/400	
Length measurement 16°C to 26°C	E0 MPE E150 MPE	2.0+3L/400	1.8+3L/400	1.8+3L/400	2.0+3L/400	
Repeatability	R0 MPL	2.0	2.0	2.0	2.0	
ISO 10360 -3:2001 <sup>5</sup>						
Rotary table	radial MPE FR	6.0	6.0	5.8	6.0	
	tangent MPE FT	6.0	6.0	5.8	6.0	
	axial MPE FA	6.0	6.0	5.8	6.0	
ISO 10360 -4:2001						
Probing accuracy scanning mode	form MPE T <sub>ij</sub> time MPT t	-	-	2.6 55 sec	-	
ISO 10360 -5:2010						
Probing accuracy touch mode	form PFTU MPE	2.8	1.7	1.6	2.8	
Multi stylus fixed head position	form PFTM MPE		6.0			
	size PSTM MPE		4.0			
	location PLTM MPE		6.0			
Multi stylus articulating head	form PFTE MPE		6.0			
	size PSTE MPE		4.0			
	location PLTE MPE		6.0			
LASER SCANNER ACCURACY <sup>6</sup>		LC15Dx	LC60Dx	L100	XC65Dx	XC65Dx-LS
ISO 10360 -8:2013						
Probing form	PForm.Sph.1x25 :Tr:ODS,MPE	7	20	15	25	35
Probing dispersion	PForm.Sph.D95% :Tr:ODS,MPL	7.6	36	26	48	60
Probing size All	PSize.Sph.All :Tr:ODS,MPE	15	30	20	45	80
Cone angle		100	125	125	115	125

## SPEEDS

Acceleration	2290 mm/sec <sup>2</sup>
Velocity	762 mm/sec

Conformance is proven when all errors of indication lie within or on the accuracy specification limits MPE/MPL.

Conformance is unproven when one or more errors of indication lie outside the accuracy specification limits MPE/MPL.

<sup>1</sup> Touch probe accuracy specifications using manufacturer specified test lengths and test sphere with empirical qualification.

E0 MPE E150 MPE Maximum volumetric length measurement error in microns where L is the measured length in millimeters.

R0 MPL Maximum repeatability value in microns using E0 values.

MPE T<sub>ij</sub> MPT t Maximum single stylus form error in microns using scanning mode with time taken in seconds.

PFTU MPE Maximum single stylus form error in microns using touch point mode.

<sup>2</sup> TP200 standard force module, EM2 module (PH20 E<sub>n</sub> MPE only), Ø4x10mm stainless steel shaft stylus, Ø4x30mm tungsten carbide shaft stylus (E<sub>n</sub> MPE only), Ø5x20mm star tungsten carbide shaft stylus (P\*TM MPE only), touch velocity 0.1m/min, approach 10mm (E<sub>n</sub> MPE only), 7mm (PFTU MPE only).

<sup>3</sup> TP200 standard force module, Ø4x10mm stainless steel shaft stylus, Ø4x30mm tungsten carbide shaft stylus (E<sub>n</sub> MPE only), Ø5x20mm star tungsten carbide shaft stylus (P\*TM MPE only), touch velocity 0.1m/min, approach 10mm (E<sub>n</sub> MPE only), 7mm (PFTU MPE only).

<sup>4</sup> SP25M SM25-1 module, SH25-1 stylus holder, Ø4x50mm tungsten carbide shaft stylus, Ø3x21mm stainless steel shaft stylus (P\*TM MPE only), touch velocity 0.1m/min, scanning velocity 0.5m/min, approach 10mm (E<sub>n</sub> MPE only), 7mm (PFTU MPE only), 50 UPR 2σ filter.

<sup>5</sup> Rotary table accuracy specifications using manufacturer specified rotary table with Ø400mm (15.7") table top.





<sup>6</sup> Laser scanner accuracy specifications for CMM with an accuracy of 2+L/350 or better using manufacturer specified test sphere with empirical qualification.

PForm.Sph.1x25:Tr:ODS,MPE Maximum probing form error in microns using 25 representative points in translatory scanning mode.

PForm.Sph.D95%:Tr:ODS,MPL Maximum probing dispersion value in microns using 95% of the measured points in translatory scanning mode.

PSize.Sph.All:Tr:ODS,MPE Maximum probing size error All in microns using all measured points in translatory scanning mode.

Cone angle Region of sphere on which the measured points are selected.

PROBE HEADS	PH10T PLUS		PH10M PLUS			PH20	
							
Head type	Indexing head		Indexing head			5-axis head	
Head positions	720		720			Infinite	
Angular tilt	0° to +105° in 7.5° steps		0° to +105° in 7.5° steps			±115°	
Angular rotation	0° to ±180° in 7.5° steps		0° to ±180° in 7.5° steps			Continuous	
Probe change rack	-		MRS ACR3			-	
TOUCH PROBES	TP20	TP200	TP20	TP200	SP25M	TP20	
Probe type	Touch trigger	Touch trigger	Touch trigger	Touch trigger	Scanning	Touch trigger	
Min. stylus diameter	0.3 (0.012)	0.3 (0.012)	0.3 (0.012)	0.3 (0.012)	0.5 (0.02)	0.3 (0.012)	
Max. stylus length	60 (2.4)	100 (3.9)	60 (2.4)	100 (3.9)	400 (15.7)	60 (2.4)	
Max. probe extension	300 (11.8)	300 (11.8)	300 (11.8)	300 (11.8)	100 (3.9)	75 (3.0)	
Min. probing force	0.055 N	0.02 N	0.055 N	0.02 N	0.1 N	0.055 N	
Stylus change rack	MCR20	SCR200	MCR20	SCR200	FCR25	TCR20	
LASER SCANNERS	-		LC15Dx	LC60Dx	XC65Dx/-LS	L100	-
Laser line width			15 (0.6)	60 (2.4)	3x 65 (2.6)	100 (3.9)	
Points/sec			70k	75k	75k	200k	
Resolution			22 µm	60 µm	65 µm	42 µm	
Standoff			68	125	107/202	135	
PERIPHERALS							
Controller	NMC100	NMC300	NMC300			UCC T5	
Handbox	NCH10	SOLO	SOLO			MCU 5	
Rotary Table	-	-	-			-	
Automation	-	●	●			-	

- Optional
- Not available

mm (inch)

**TECHNICAL FEATURES**

X axis guideway	Granite dovetail guideway with bellows covers on primary bridge leg
Y axis guideway	Mono-crystalline alumina ceramic guideway 220 x 102mm (8.7 x 4.0inch) with bellows covers
Z axis guideway	Mono-crystalline alumina ceramic guideway 70 x 70mm (2.8 x 2.8inch) with top-hat cover
X axis friction drive	Chrome-plated hardened steel drive bar with preloaded V roller and DC servomotor
Y axis friction drive	Stainless steel drive belt with preloaded rollers and DC servomotor
Z axis friction drive	Stainless steel drive belt with preloaded rollers and DC servomotor
Linear encoders	0.05µm stainless steel ribbon scale and optical read-head Renishaw TONiC™ system
Counterbalance	Fully adjustable pneumatic Z axis counter balance
Granite table	Granite table flatness according to DIN 876/III : Grade 0
Table inserts	Grid pattern of M10 x 1.5 threaded table inserts on 250 (9.8) center spacing
Air bearings	Single orifice multi-groove air bearings with 5µm air cushion on all axes
Temperature compensation	Automatic temperature compensation for work piece and all axes
Anti-vibration	Passive elastomer anti-vibration as standard, active pneumatic anti-vibration optional

**ENVIRONMENTAL REQUIREMENTS**

Ambient temperature	Standard temperature range:	18°C to 22°C
	Extended temperature range	16°C to 26°C
Temperature gradient	Standard temperature range:	1°C/h 2°C/24h 1°C/m
	Extended temperature range:	1°C/h 5°C/24h 1°C/m
Operating temperature	10°C to 30°C	
Relative humidity	20% to 80% non-condensing	
Floor vibration	Passive anti-vibration:	Max. 1.27µm peak-to-peak over 3.5 to 90Hz range
	Active anti-vibration:	Specification on request

**SUPPLY REQUIREMENTS**

Power supply	115V/20A or 230V/13A 50 to 60Hz single phase regulated to within -5% to +10%	
Air consumption	Passive anti-vibration:	2.7 SCFM (75 NI/min)
	Active anti-vibration:	4.2 SCFM (120 NI/min)
Air supply	Min. air supply pressure 6.2 bar (90 psi)	
Air quality	Dew point:	2°C
	Air temperature:	Within +/- 2°C of ambient temperature
	Solids:	Max. particle size 1.0µm and max. concentration 1mg/cu.m of air
	Oil/hydrocarbons:	Max. concentration 0.1mg/cu.m of air

**WARRANTY**



12 months' warranty as standard, extended warranty available on request  
 Unique 10-year original accuracy guarantee as standard  
 Terms and conditions apply see LK Metrology website for full details

**CONFORMITY**



Full CE certification in accordance with the following directives:  
 Machinery directive 2006/42/EC  
 Low voltage directive 2014/35/EC  
 Electromagnetic directive 2014/30/EC